

TORINO

TRINCIA LATERALE PROFESSIONALE | PROFESSIONAL SIDE MOWER

MOD : 160 | 180 | 200 | 220

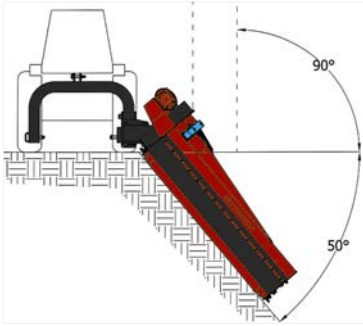

Ø 6-8 cm

CARATTERISTICHE | FEATURES



Utensili
Tools



Accumulatore oleopneumatico
Oleo-pneumatic accumulator



Sicurezza meccanica
Mechanical safety



Rullo smontabile
Bolted roller

- Attacco terzo punto: cat. 2 | Type attelage: cat. 2
- Slitte laterali regolabili | Adjustable side skids
- Rullo autopulente regolabile e smontabile
Self-cleaning adjustable and bolted roller
- Tendicinghia automatico e ingrassaggio centralizzato
Centralised greaser and automatic belt tightener
- Gruppo moltiplicatore con ruota libera interna
Gearbox with free wheel
- Spostamento idraulico laterale con sistema di bloccaggio meccanico
Hydraulic side offset with mechanical stop system
- Ammortizzatore e accumulatore oleopneumatico
Oleo-pneumatic shock absorber and accumulator
- Sicurezza meccanica | Mechanical safety

UTENSILI | TOOLS

MAZZA
HAMMER







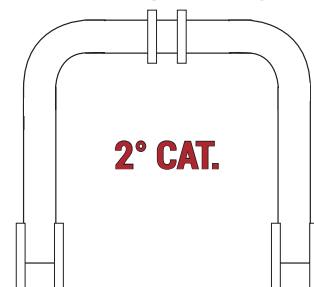

COLTELLO A Y
Y FLAILS



ATTACCO TERZO PUNTO THREE POINT HITCH



SPECIFICHE TECNICHE TECHNICAL SPECIFICATIONS					
MODELLO MODEL		160	180	200	220
	LARGHEZZA LAVORO WORK WIDTH (cm)	160	180	200	220
	LARGHEZZA MACCHINA WIDTH MACHINE (cm)	185	215	227	245
	PESO WEIGHT	730	790	815	840
	N° MARTELLI e COLTELLI HAMMER and KNIFE	34 68	38 76	44 88	48 96
	N° CINGHIE SPBX BELTS SPBX	4	4	4	4
	SCATOLA STANDARD STANDARD GEARBOX	65-110		80-120	

MODELLO MODEL		160	180	200	220
€	PREZZI PRICES	SU RICHIESTA ON REQUEST			

RIF.		160	180	200	220
SPOSTAMENTO LATERALE (cm) SIDE OFFSET (cm)	A	160	180	200	220
	B	195	195	195	195
	C	80	80	80	80
	D	215	235	255	275
	E	223	223	223	223
	F	135	135	135	135

OPZIONI & ACCESSORI OPTIONS & ACCESSORIES
CARDANO 1700 mm PTO SHAFT 1700mm
CARDANO OMOCINETICO WIDE ANGLE PTO SHAFT
VERSIONE SPOSTAMENTO SX LEFT HAND SDE SHFT
CATENE PARASASSI FRONT PROTECTION WITH CHAINS

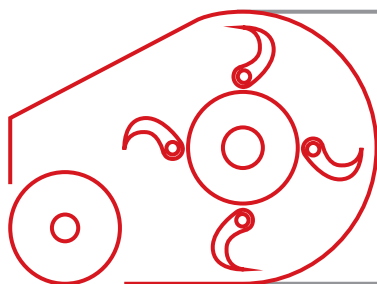
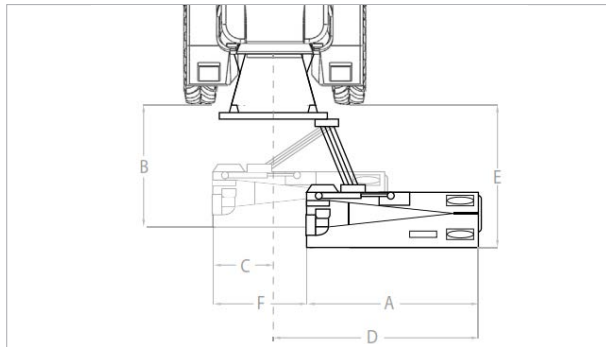

Ø del rotore Ø of rotor	180 mm
Giri rotore RPM	1800 g/min
Presenza di forza PTO	540
Ø del rullo Ø of roller	177 mm